

1340L Offal Bin

Nestable ¹

Forklift Rotatable ³

Design Strength:

- **Tough LDPE - 10mm thickness**
- **Box Section Top Rim**
(no open edge to crack from)
- **¹Continuous Nesting Rim**
(less wall flex and more strength)

FDA Approved Food Grade LDPE

Mould In Graphics

(company + numbering options)

65mm Drainage Bung

³Galv Steel Fork Insert option

1200mm² Single Skin Lid



[Full Specifications on Page 2 below](#)

Designed and manufactured in New Zealand

1340L Offal Bin

Code	BN222
Volume	1340L
Height	1400 mm
Top Rim	1200 mm²
Nest Rim	1125 mm²
Base	950 mm²
Wall Thickness	10 mm
Material	LDPE

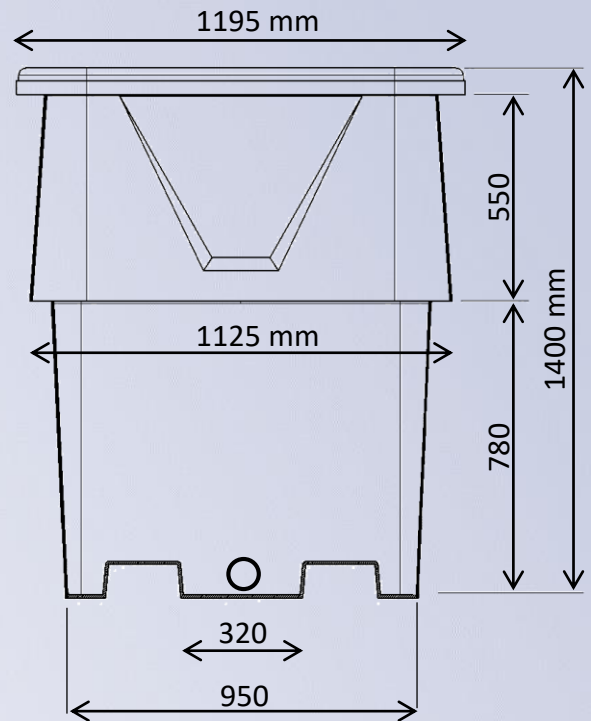

Box Section Top Rim -
(cut out showing 20mm thickness)

Contact us to discuss the best bin for you